

LED UK

Echo Square

The Echo LED is a square 300 x 300mm surface wall/ceiling luminaire constructed from die cast aluminium. Rated IP65 & IK10 providing an aesthetic look with vandal resistance. The luminaire available in 20, 30 or 40 Watts. The light distribution is symmetrical with a even halo light effect.

- Cast Aluminium
- IP65 rated
- IK10 rated
- Instant on - no flicker
- Environmentally Friendly - No mercury or lead enters the environment
- No RF and electronic magnetic interference
- Over 50,000 hours life span



General

Dimensions	300 x 300mm Height 87mm
Weight	1.7kg
Installation	Wall/Ceiling Surface
Voltage	AC85V-265V 50/60Hz
Certification	CE, ROHS
Warranty	5 Years
IP Rating	IP65
Impact Rating	IK10

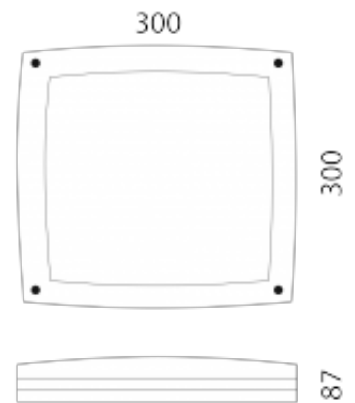

Performance

Colour Rendering	Ra>80
Longevity	50,000 hours
System Power	20W / 30W / 40W
Exit Lumens	1600lm / 2400lm / 3200lm
Efficiency	80.0 l/W
Compliance	Building Regulations ETL (Energy Technology List) ECA (Enhanced Capital Allowance) SKA Rating

Available options

Wattage	20W - 1600Lm, 30W - 2400Lm, 40W - 3600Lm
Colour Temperature	3000K, 4000K
Body	White Painted Finish, Black Painted Finish
Microwave Sensor	Not Required, Microwave Sensor
Dimming	Fixed Output, 1-10V, DALI Dimming, Switch Dimming
Emergency	Not Required, 3 Hour Facility, 3 Hour Self Test, 3 Hour Central Test, 3 Hour Central Battery

Product Code: ECH-SQ